

# ***PARTNER***

Illustrated Parts List 2000-05 CD

***K1250 ACTIVE*** 1998-2000

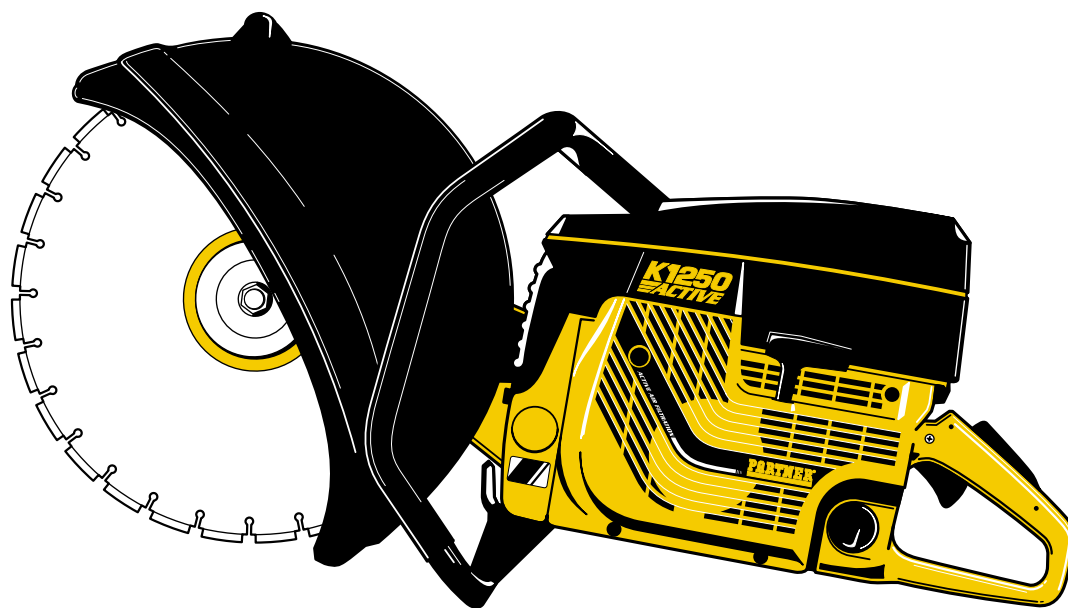

108 30 00-60

---

**PARTNER®**

# A

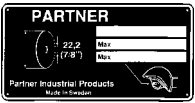
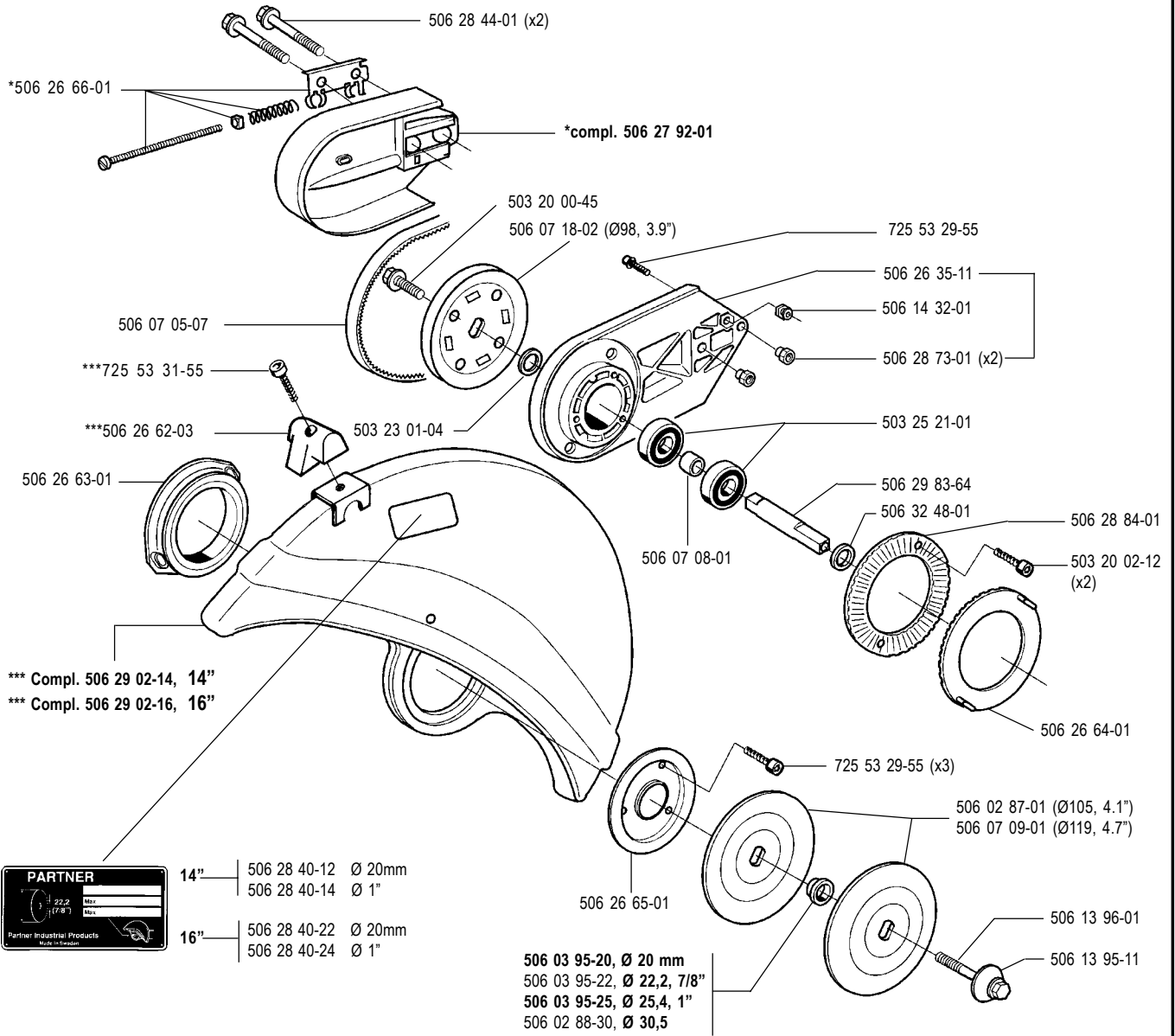

# B

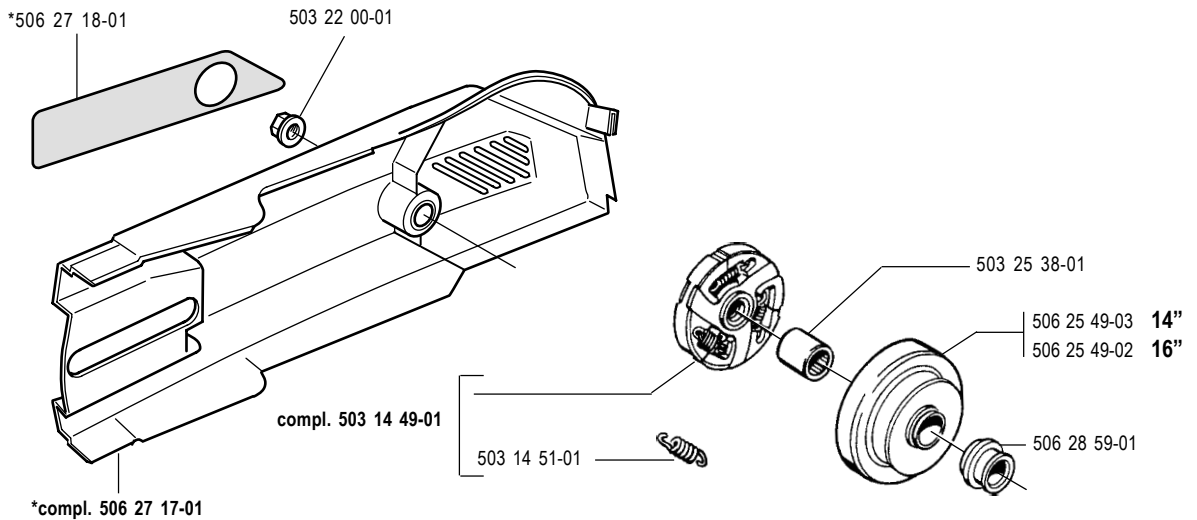

C

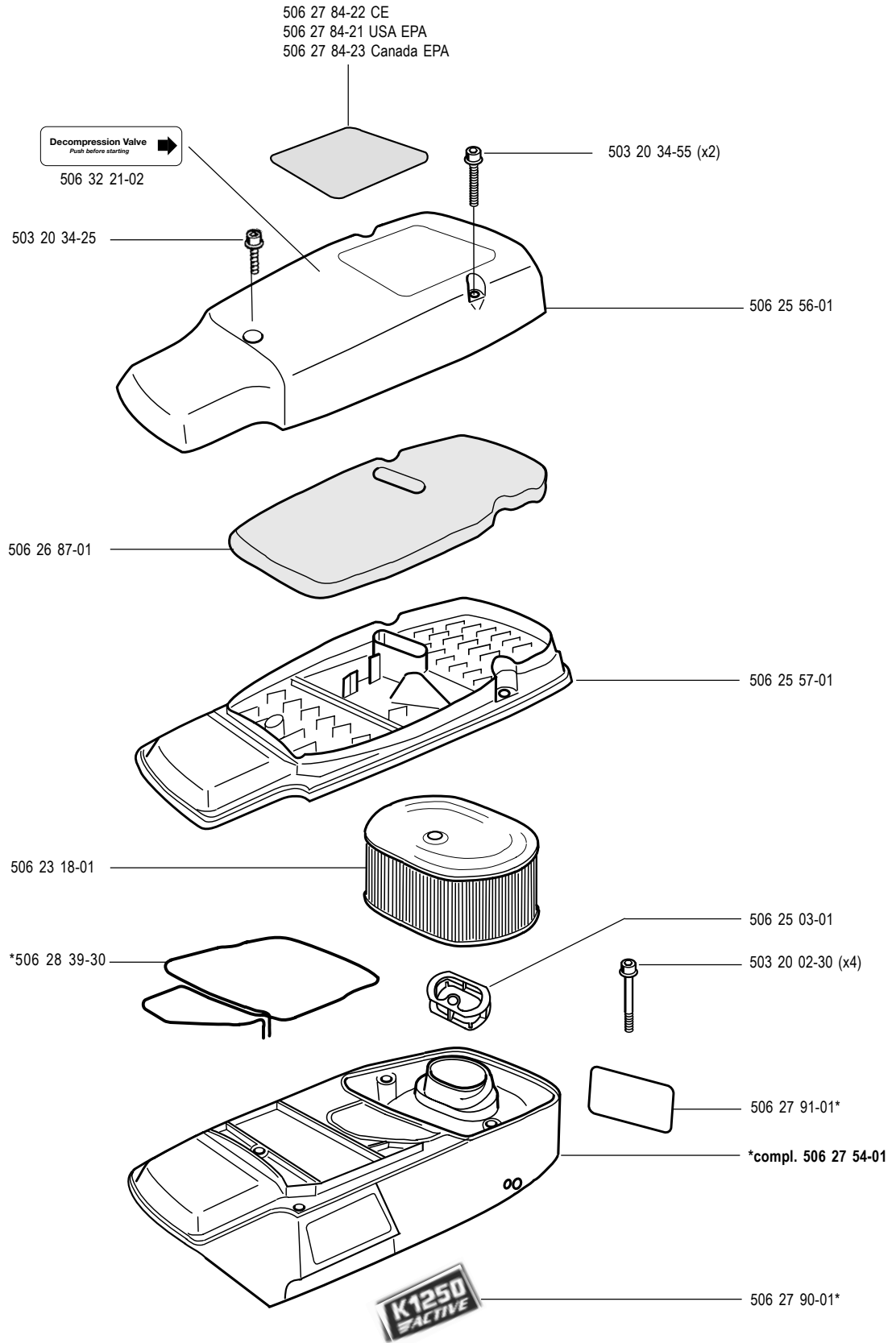

**D** Cylinder and piston \*compl. 506 29 42-71

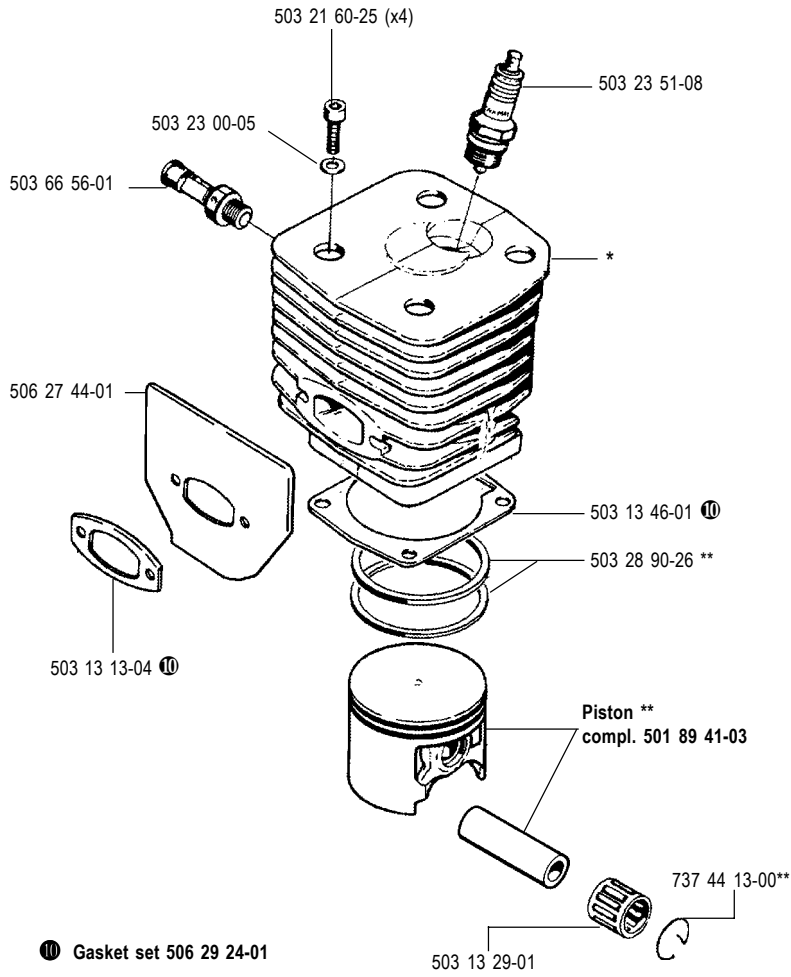

**E** \*compl. 503 14 20-72

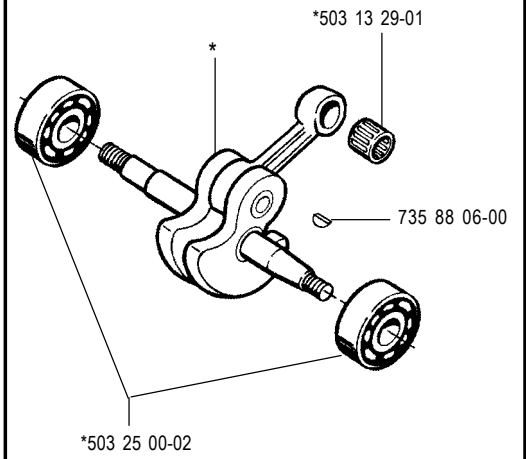

**F** \*compl. 503 13 00-02

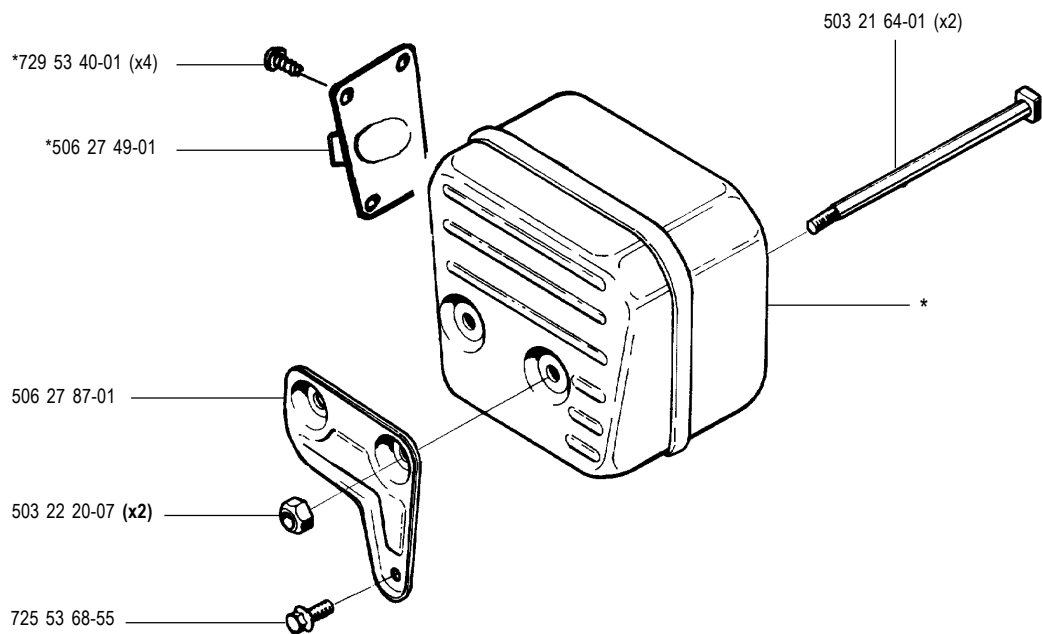

# G

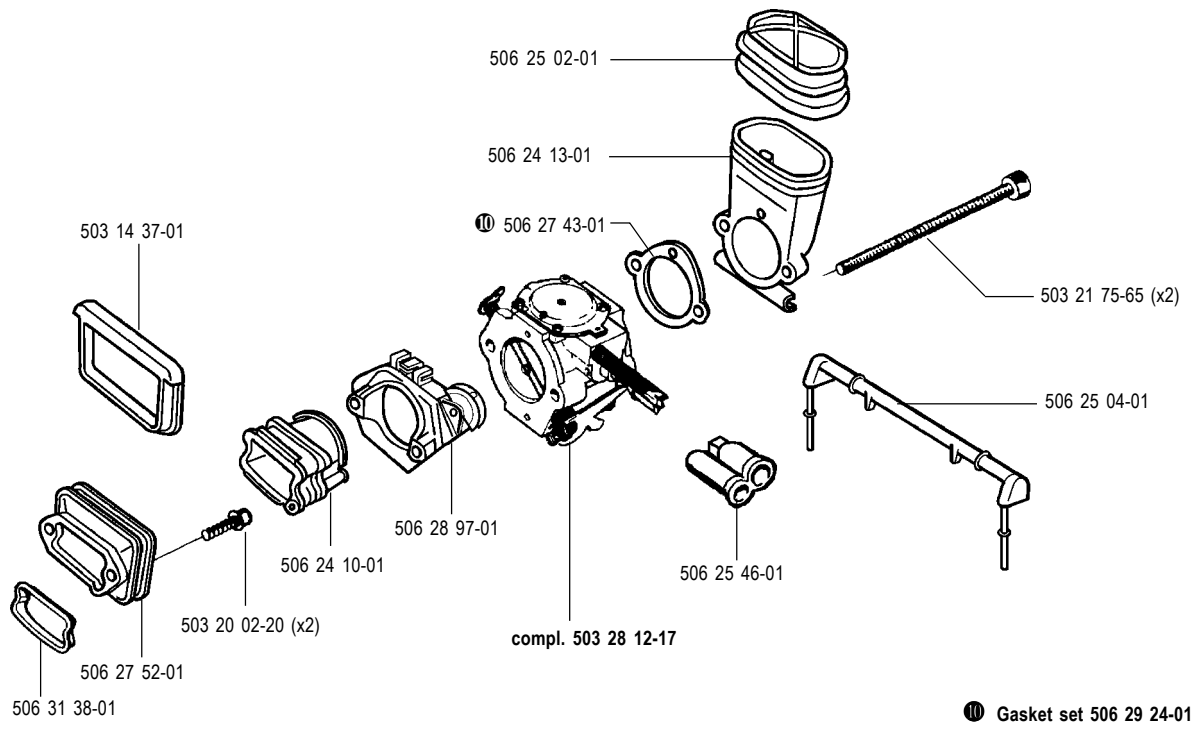

# H

## Crankcase \*compl. 501 89 25-73

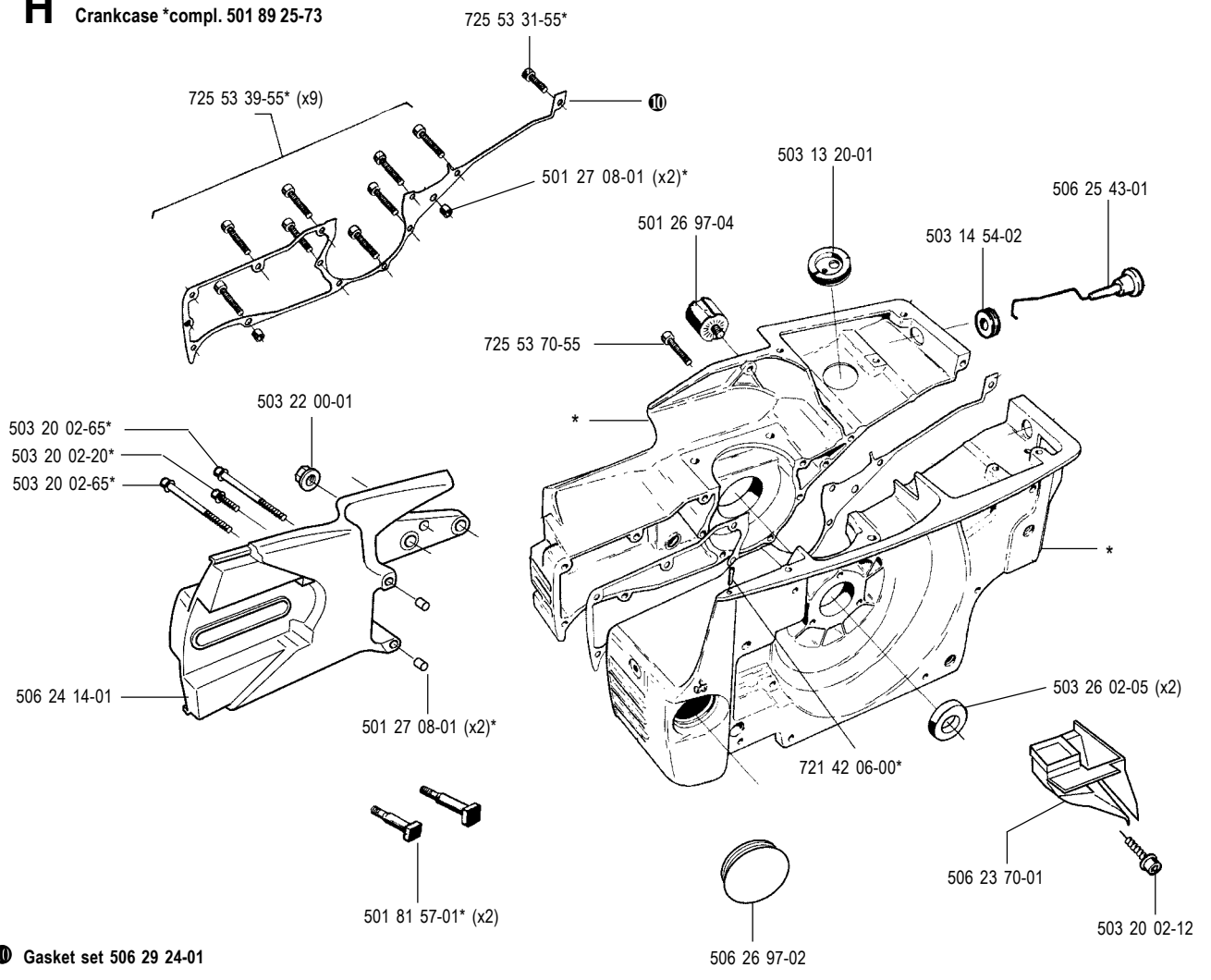

# J

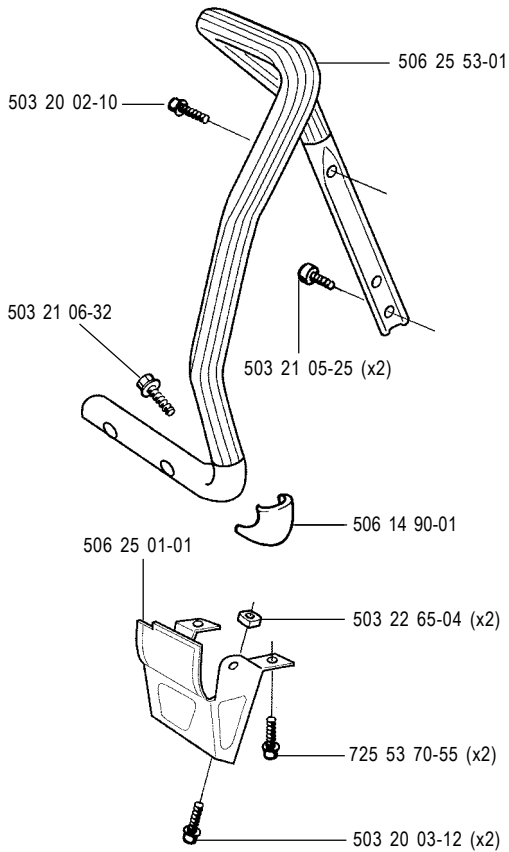

# K Tank unit \*compl. 503 14 21-07

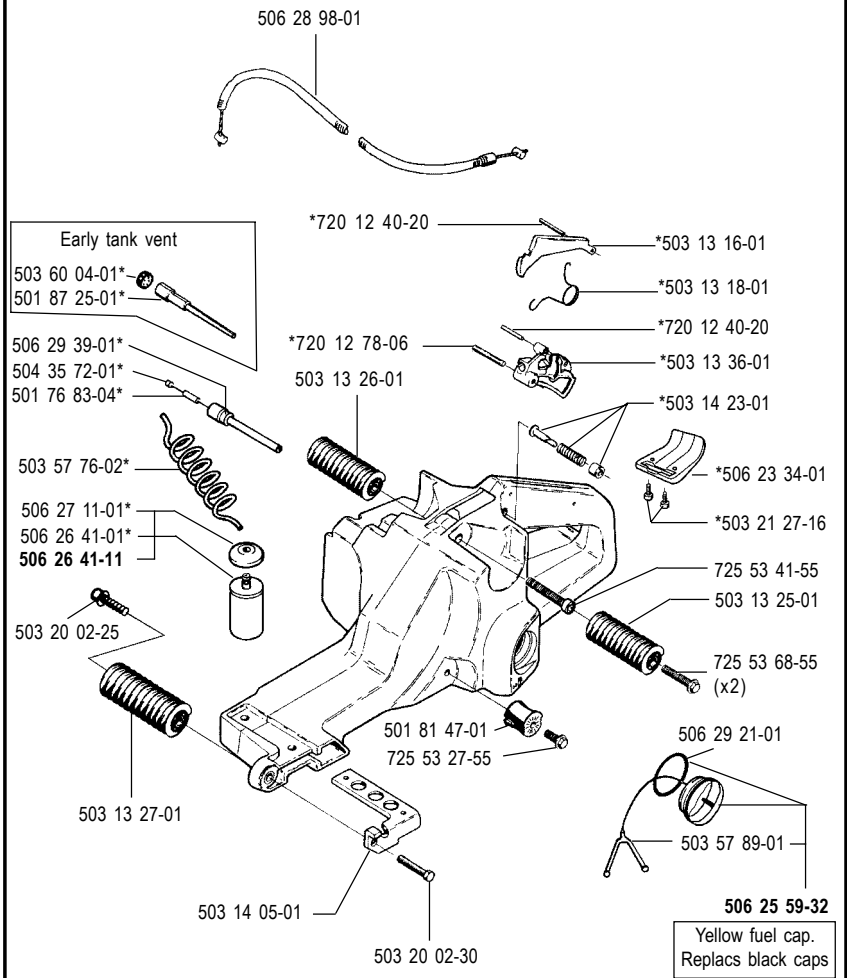

# L \* Flywheel compl. 501 89 50-03

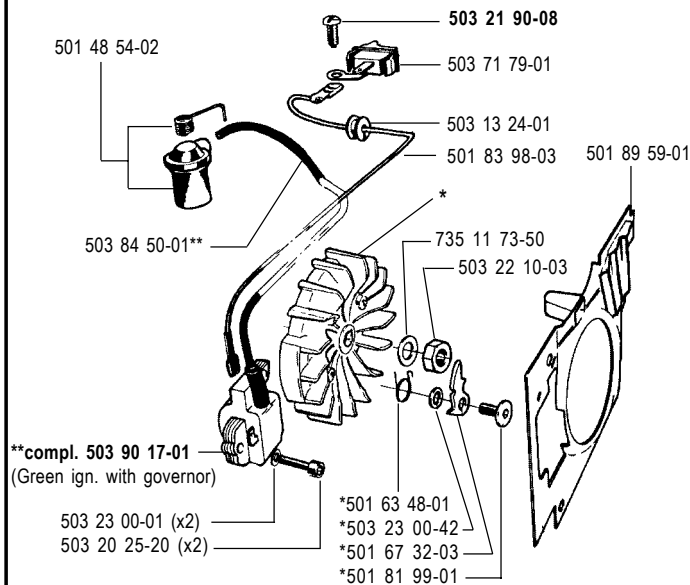

# M \* Starter compl. 506 27 55-01

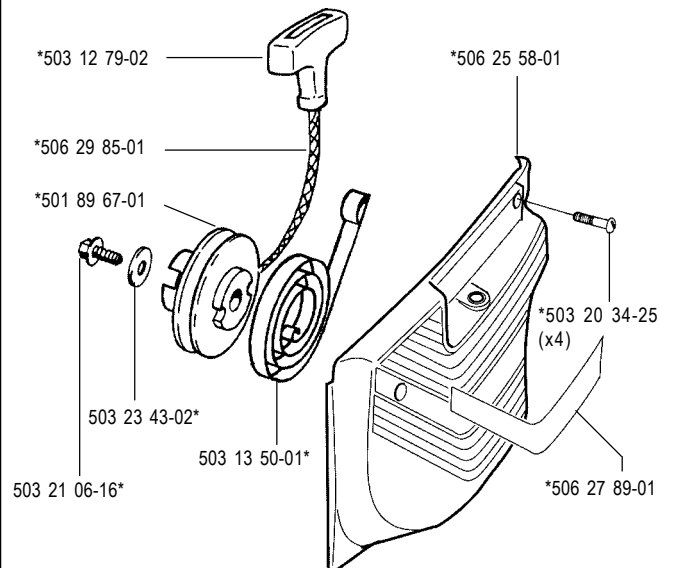

**N** Carburettor compl. 503 28 12-17  
Walbro WG 9

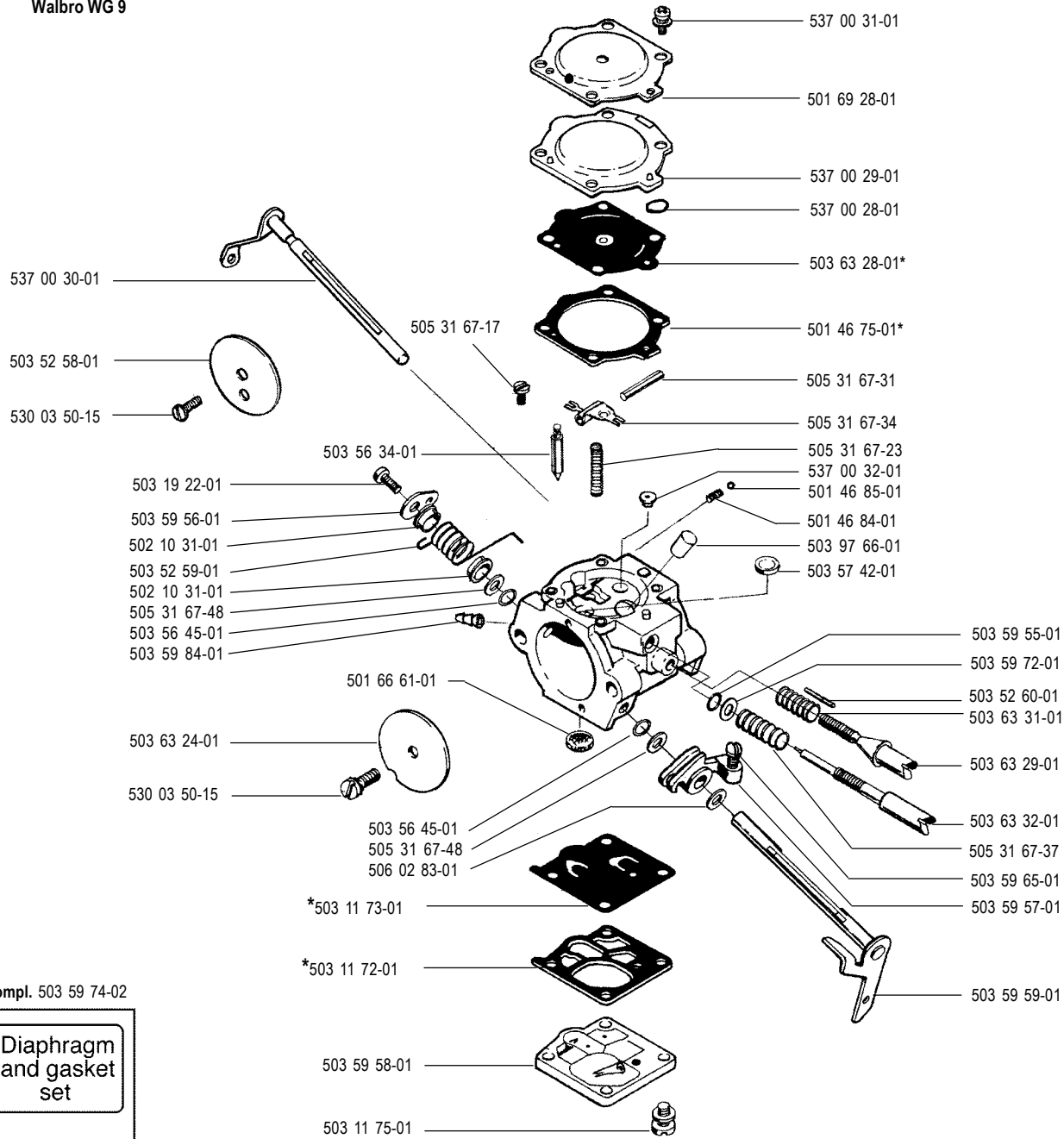

\* compl. 503 59 74-02

Diaphragm and gasket set

**O**

**PARTNER**  
Packingsatz  
Gasket set  
Dichtungssatz

⑩ 506 29 24-01

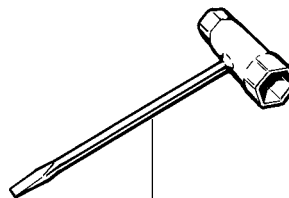

501 69 17-02

No.	Pos.	Denomination	No.	Pos.	Denomination	No.	Pos.	Denomination
501 26 97-04	H	Antivib element	503 23 00-42	L	Washer 10x5,3x1	506 25 57-01	C	Filter base
501 27 08-01	H	Sleeve	503 23 01-04	A	Washer 15x21	506 25 58-01	M	Starter housing
501 46 75-01	N	Gasket	503 23 43-02	M	Washer	506 25 59-22	K	Fuel cap
501 46 84-01	N	Spring	503 23 51-08	D	Spark plug RCJ7Y	506 26 35-11	A	Housing
501 46 85-01	N	Ball	503 25 00-02	E	Ball bearing 6203C3QE6	506 26 41-01	K	Fuel filter
501 48 54-02	L	Spark plug conn.kit	503 25 21-01	A	Ball bearing	506 26 41-11	K	Fuel filter cmpl.
501 63 48-01	L	Spring	503 25 38-01	B	Needle bearing	506 26 62-03	A	Handle
501 66 61-01	N	Screen	503 26 02-05	H	Sealing ring	506 26 63-01	A	Lining
501 67 32-03	L	Pawl	503 28 12-17	G,N	Carburettor	506 26 64-01	A	Flange
501 69 17-02	O	Combination tool	503 28 90-26	D	Piston ring	506 26 65-01	A	Flange
501 69 28-01	N	Cover	503 52 58-01	N	Choke flap	506 26 66-01	A	Tensioner
501 76 83-04	K	Hose	503 52 59-01	N	Spring	506 26 87-01	C	Foam filter
501 81 47-01	K	Antivib element	503 52 60-01	N	Pin	506 26 97-02	H	Plug
501 81 57-01	H	Bolt	503 56 34-01	N	Inlet needle	506 27 11-01	K	Fuel filter weight
501 81 99-01	L	Screw M5x14	503 56 45-01	N	Sealing ring	506 27 17-01	B	Clutch cover
501 83 98-03	L	Lead	503 57 42-01	N	Welch plug	506 27 18-01	B	Decal
501 87 25-01	K	Tank vent	503 57 76-02	K	Hose 300 mm	506 27 43-01	G	Gasket
501 89 25-73	H	Crankcase cpl.	503 57 89-01	K	Holder	506 27 44-01	D	Cooling plate
501 89 41-03	D	Piston cpl.	503 59 55-01	N	O-ring	506 27 49-01	F	Exhaust pipe
501 89 50-03	L	Flywheel cpl.	503 59 56-01	N	Lever	506 27 52-01	G	Flange, intake
501 89 59-01	L	Air conductor	503 59 57-01	N	Lever	506 27 54-01	C	Cylinder cover
501 89 67-01	M	Pulley	503 59 58-01	N	Cover	506 27 55-01	M	Starter cpl.
502 10 31-01	N	Bushing	503 59 59-01	N	Throttle shaft	506 27 84-21	C	Decal USA EPA
503 11 72-01	N	Gasket	503 59 65-01	N	Screw	506 27 84-22	C	Decal CE
503 11 73-01	N	Diaphragm	503 59 72-01	N	Washer	506 27 84-23	C	Decal Canada EPA
503 11 75-01	N	Screw with washer	503 59 74-02	N	Diaphragm set	506 27 87-01	F	Support, muffler
503 12 79-02	M	Starter handle	503 59 84-01	N	Nipple	506 27 89-01	M	Decal
503 13 00-02	F	Muffler cpl.	503 60 04-01	K	Plug	506 27 90-01	C	Decal K1250
503 13 13-04	D	Gasket	503 63 24-01	N	Throttle valve	506 27 91-01	C	Decal, instruction
503 13 16-01	K	Throttle catch	503 63 28-01	N	Diaphragm	506 27 92-01	A	Cover, belt
503 13 18-01	K	Spring	503 63 29-01	N	Screw (idle speed)	506 28 39-30	C	Sealing
503 13 20-01	H	Grommet	503 63 31-01	N	Spring	506 28 40-12	A	Label 14-20
503 13 24-01	L	Grommet	503 63 32-01	N	Screw (low speed)	506 28 40-14	A	Label 14-25,4
503 13 25-01	K	Antivib element	503 66 56-01	D	Valve	506 28 40-22	A	Label 16-20
503 13 26-01	K	Antivib element	503 71 79-01	L	Stop switch	506 28 40-24	A	Label 16-25,4
503 13 27-01	K	Antivib element	503 84 50-01	L	Ignition wire	506 28 44-01	A	Bolt
503 13 29-01	D,E	Needle bearing	503 90 17-01	L	Ignition module			
						506 28 59-01	B	Spacer sleeve
503 13 36-01	K	Throttle lever	503 97 66-01	N	Jet	506 28 73-01	A	Nut
503 13 46-01	D	Gasket	504 35 72-01	K	Tank vent filter	506 28 84-01	A	Flange
503 13 50-01	M	Recoil spring	505 31 67-17	N	Screw	506 28 97-01	G	Flange, intake
503 14 05-01	K	Plate	505 31 67-23	N	Lever spring	506 28 98-01	K	Throttle wire cpl.
503 14 20-72	E	Crankshaft cpl.	505 31 67-31	N	Lever axle	506 29 02-14	A	Guard 14"
503 14 21-07	K	Tank unit cpl.	505 31 67-34	N	Lever	506 29 02-16	A	Guard 16"
503 14 23-01	K	Throttle catch, kit	505 31 67-37	N	Spring	506 29 21-01	K	Gasket
503 14 37-01	G	Sealing	505 31 67-48	N	Washer	506 29 24-01	O	Gasket set
503 14 49-01	B	Clutch cpl.	506 02 83-01	N	Washer	506 29 39-01	K	Tank vent
503 14 51-01	B	Clutch spring	506 02 87-01	A	Flange washer Ø105	506 29 42-71	D	Cylinder cpl
503 14 54-02	H	Grommet	506 03 95-20	A	Bushing	506 29 83-64	A	Arbor shaft
503 19 22-01	N	Screw	506 03 95-22	A	Bushing	506 29 85-01	M	Starter rope
503 20 00-45	A	Screw	506 03 95-25	A	Bushing	506 31 38-01	G	Insert
503 20 02-10	J	Screw	506 07 05-07	A	Belt	506 32 21-02	C	Decal "Decompression"
503 20 02-12	A,H,J,K	Screw	506 07 08-01	A	Spacer	506 32 48-01	A	Sleeve
503 20 02-20	G,H	Screw	506 07 09-01	A	Flange washer Ø 119	530 03 50-15	N	Screw, shutter
503 20 02-25	K	Screw	506 07 18-02	A	Pulley	537 00 28-01	N	O-ring
503 20 02-30	C,K	Screw	506 13 95-11	A	Washer	537 00 29-01	N	Insert
503 20 02-65	H	Screw MC6SF 5x65	506 13 96-01	A	Screw	537 00 30-01	N	Choke shaft
503 20 03-12	J	Screw MC6SF 5x12E	506 14 32-01	A	Catch	537 00 31-01	N	Screw
503 20 25-20	L	Screw	506 14 90-01	J	Support	537 00 32-01	N	Jet
503 20 34-25	C,M	Screw	506 23 18-01	C	Housing	720 12 40-20	K	Pin
503 20 34-55	C	Screw	506 23 34-01	K	Protector	720 12 78-06	K	Pin 4x35
503 21 05-25	J	Screw	506 23 70-01	H	Air jet	721 42 06-00	H	Pin
503 21 06-16	M	Screw	506 24 10-01	G	Intake pipe	725 53 27-55	K	Screw
503 21 06-32	J	Screw	506 24 13-01	G	Air horn	725 53 29-55	A	Screw MC6S 5x16
503 21 27-16	K	Screw	506 24 14-01	H	Cutting arm	725 53 31-55	A,H	Screw MC6S 5x20
503 21 60-25	D	Screw	506 25 01-01	J	Support	725 53 39-55	H	Screw MC6S 5x40
503 21 64-01	F	Bolt	506 25 02-01	G	Insert	725 53 41-55	K	Screw MC6S 5x50
503 21 75-65	G	Bolt	506 25 03-01	C	Insert	725 53 68-55	K	Screw MC6S 6x16
503 21 90-08	L	Screw	506 25 04-01	G	Support, carburettor	725 53 70-55	H,J	Screw MC6S 6x20
503 22 00-01	B,H	Nut M6MF M8	506 25 43-01	H	Choke control	729 53 40-01	F	Screw
503 22 10-03	L	Nut M 10x1	506 25 46-01	G	Guide	735 11 73-50	L	Spring washer
503 22 20-07	F	Nut	506 25 49-02	B	Drive wheel (16")	735 88 06-00	E	Woodruff key
503 22 65-04	J	Nut	506 25 49-03	B	Drive wheel (14")	737 44 13-00	D	Clip
503 23 00-01	L	Washer 4,2 x 9	506 25 53-01	J	Handle			
503 23 00-05	D	Washer 6.5x11	506 25 56-01	C	Filter cover			